

# BFL 2011

for generator sets

12 - 46 kW | 15 - 62 hp at 1500/1800 min<sup>-1</sup> | rpm

EU Stage II / US EPA Tier 2

- Oil-cooled 2, 3 and 4-cylinder aspirated engine in inline construction with integrated cooling system.
- 4-cylinder also with turbocharging.
- Direct injection with single injection pumps and optional electronic governor.
- Low fuel consumption due to optimised combustion.

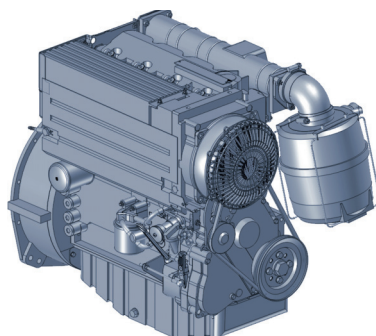

- Long oil change intervals of up to 1000 hours.
- Minimised running costs due to low maintenance need and little wear.
- High reliability combined with durability. No corrosion or cavitation due to oil cooling and lubrication.
- A very good load response ensures an immediate power supply.

## Technical data

Engine type		F2L 2011	F3L 2011	F4L 2011	BF4L 2011
No. of cylinders		2	3	4	4
Bore/stroke	mm   in	94/112   3.7/4.4	94/112   3.7/4.4	94/112   3.7/4.4	94/112   3.7/4.4
Displacement	l   cu in	1.6   95	2.3   142	3.1   190	3.1   190
Weight (incl. cooler and fan)	kg   lb	212   468	254   560	293   646	295   649
Governing standard <sup>1)</sup>		G2	G2	G2	G2

## 50 Hz / 1500 min<sup>-1</sup>

Power		F2L 2011	F3L 2011	F4L 2011	BF4L 2011
Continuous Power (COP) <sup>2)</sup>	kW   hp	11.5   15.4	18.1   24.3	26.4   35.4	34.8   46.7
Prime Power (PRP) <sup>3)</sup>	kW   hp	12.1   16.2	19.1   25.6	27.8   37.3	36.6   49.1
Limited Time Power (LTP) <sup>4)</sup>	kW   hp	12.7   17.0	20.1   27.0	29.1   39.2	38.4   51.5
Fan power consumption	kW   hp	0.1   0.1	0.1   0.1	0.2   0.2	0.3   0.3
Typical Generator Output COP <sup>5)</sup>	kVA	13	20	30	39
Typical Generator Output PRP <sup>5)</sup>	kVA	13	21	31	41
Typical Generator Output LTP <sup>5)</sup>	kVA	14	22	33	43

## 60 Hz / 1800 min<sup>-1</sup>

Power		F2L 2011	F3L 2011	F4L 2011	BF4L 2011
Continuous Power (COP) <sup>2)</sup>	kW   hp	13.7   18.4	21.6   29.0	31.4   42.1	41.4   55.5
Prime Power (PRP) <sup>3)</sup>	kW   hp	14.4   19.3	22.7   30.4	33.1   44.4	43.6   58.5
Limited Time Power (LTP) <sup>4)</sup>	kW   hp	15.2   20.4	23.9   32.1	34.8   46.7	45.9   61.6
Fan power consumption	kW   hp	0.1   0.1	0.1   0.1	0.3   0.3	0.4   0.4
Typical Generator Output COP <sup>5)</sup>	kWe	12	19	28	37
Typical Generator Output PRP <sup>5)</sup>	kWe	13	21	30	39
Typical Generator Output LTP <sup>5)</sup>	kWe	13	22	31	41

1) According to ISO 8528-5.

2) Continuous Power: No time limitation, plus 10% additional power for governing purpose only.

3) Prime Power: Average power output ≤ 80%, no time limitation, plus 5% additional power for governing purpose only.

4) Limited Time Running Power: For up to 500 h/year, thereof a maximum of 300 h/year continuous running.

5) In consideration of a generator efficiency level of 89 - 90 % and a power factor of 0.8.

The data on this data sheet are for information purposes only and are not binding values. The data in the quotation is definitive.

The engine company.



## 50 Hz / 1500 min<sup>-1</sup>

Fuel Consumption (PRP) <sup>1)</sup>		F2L 2011	F3L 2011	F4L 2011	BF4L 2011
Fuel consumption 25% load	g/kWh   lb/hph	301   0.49	299   0.49	264   0.43	259   0.43
Fuel consumption 50% load	g/kWh   lb/hph	246   0.40	236   0.39	226   0.37	223   0.37
Fuel consumption 75% load	g/kWh   lb/hph	235   0.39	224   0.37	216   0.36	226   0.37
Fuel consumption 100% load	g/kWh   lb/hph	244   0.40	233   0.38	222   0.36	237   0.39

Heat balance & cooling system		F2L 2011	F3L 2011	F4L 2011	BF4L 2011
Heat dissipation (engine radiator) <sup>2)</sup>	kW   hp	-	-	-	-
Heat dissipation (convection)	kW   hp	-	-	-	-
Cooling air flow	m <sup>3</sup> /h   cfm	1065   627	1075   633	1490   877	1885   1109

Inlet & exhaust data		F2L 2011	F3L 2011	F4L 2011	BF4L 2011
max. intake depression	mbar   psi	20   0.29	20   0.29	20   0.29	20   0.29
Combustion air volume	m <sup>3</sup> /h   cfm	61   36	86   51	122   72	160   94
max. exhaust gas temperature	°C   °F	510   950	510   950	510   950	600   1112
Exhaust gas flow	m <sup>3</sup> /h   cfm	169   99	236   139	337   198	445   262

## 60 Hz / 1800 min<sup>-1</sup>

Fuel Consumption (PRP) <sup>1)</sup>		F2L 2011	F3L 2011	F4L 2011	BF4L 2011
Fuel consumption 25% load	g/kWh   lb/hph	304   0.50	294   0.48	280   0.46	265   0.44
Fuel consumption 50% load	g/kWh   lb/hph	249   0.41	237   0.39	230   0.38	221   0.36
Fuel consumption 75% load	g/kWh   lb/hph	237   0.39	225   0.37	220   0.36	219   0.36
Fuel consumption 100% load	g/kWh   lb/hph	245   0.40	236   0.39	230   0.38	224   0.37

Heat balance & cooling system		F2L 2011	F3L 2011	F4L 2011	BF4L 2011
Heat dissipation (engine radiator) <sup>2)</sup>	kW   hp	-	-	-	-
Heat dissipation (convection)	kW   hp	2.5   3.4	3.4   4.6	5.0   6.7	6.5   8.7
Cooling air flow	m <sup>3</sup> /h   cfm	1275   750	1290   759	1790   1054	2265   1333

Inlet & exhaust data		F2L 2011	F3L 2011	F4L 2011	BF4L 2011
max. intake depression	mbar   psi	20   0.29	20   0.29	20   0.29	20   0.29
Combustion air volume	m <sup>3</sup> /h   cfm	68   40	104   61	137   81	191   112
max. exhaust gas temperature	°C   °F	510   950	520   968	540   1004	560   1040
Exhaust gas flow	m <sup>3</sup> /h   cfm	199   117	295   174	400   235	531   313

1) Refers to diesel with a density of 0.835 kg/dm<sup>3</sup> at 15°C | 6.96 lb/US gallon at 60°F.

2) The heat quantities are valid for the dimensioning of the cooling system.

## Dimensions

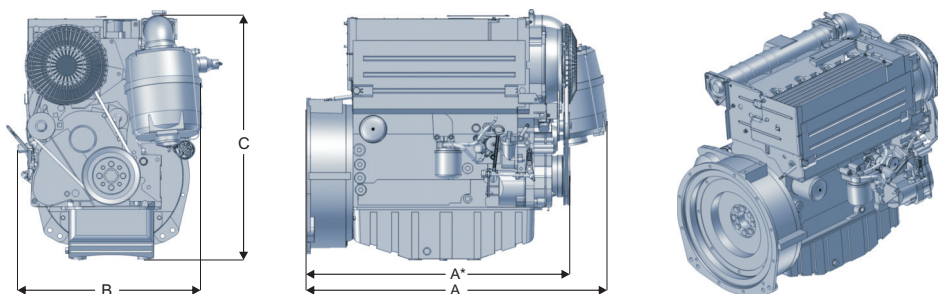

		A	A*	B	C
F2L 2011	mm   in	645   25	540   21	590   23	705   28
F3L 2011	mm   in	755   30	650   26	590   23	700   28
F4L 2011	mm   in	870   34	760   30	590   23	720   28
BF4L 2011	mm   in	-	780   31	530   21	705   28

Note: The engine dimensions and weights vary depending on the scope of delivery.

For more information please contact the DEUTZ AG Köln or the responsible sales partner.

